

Liquid Weighing / Filling Machine

Model : VC505-NWF-PA-EX Ex-Proof Pail Filler

Container Wt (kg)	Fill Rate (per container)
Up to 30	25 – 30 sec*
Up to 60	30 – 45 sec*
Up to 300	45 – 60 sec*

* Based on water @30 PSI and 110 GPM

- Filling of chemical liquid including viscose product like latex paint, oil, lacquers and paste
- Filling of container height from 300–1000mm
- Design with interchange filling lance for easy cleaning and quick product change over
- Simple operation
- Easy handling
- Microprocessor weighing system
- Available in top fill and bottom fill (for foamy product) design

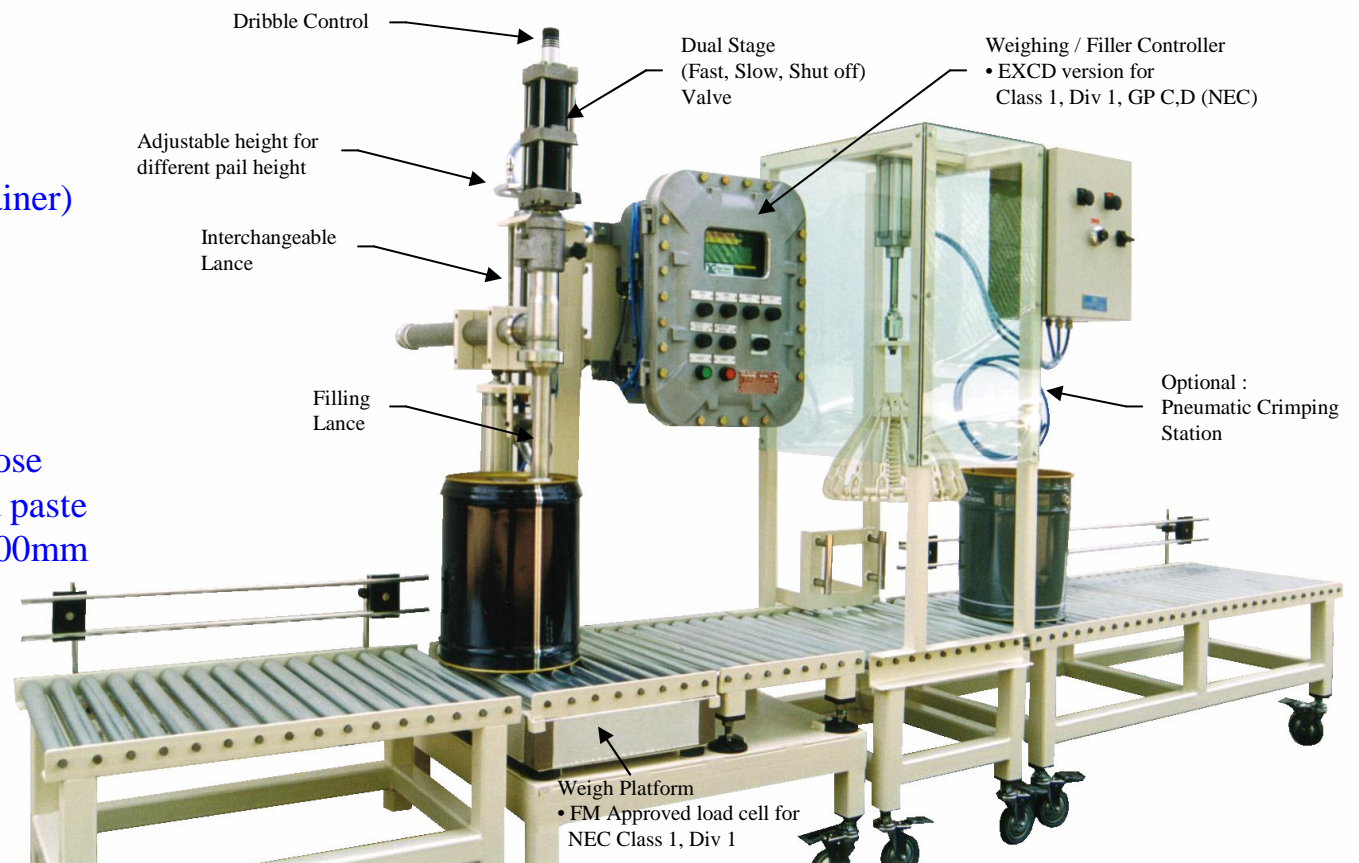

◆ Explosion-Proof Pail Filler c/w pneumatic pail crimper

Drum Net Weight Filler

Model	VC505-NWF-PA-EX
Display Graduation	1 part of 3000 full scale
Accuracy	< $\pm 0.2\%$ of full scale
Construction	Wetted parts SUS 316 with teflon seals / seats Non-wetted parts structural steel with epoxy paint Adjustable height of filling lance to accommodate different container heights, drip tray, bung hole locator, interchange filling lance
Weighing Controller	VC 505, Virtual Measurements & Control, Inc , USA High resolution LCD (64 x 240) Graphic 1.25" x 5" display with 0.8" digit and 60 character text 17 button membrane keypads with tactile keys RF / EMF protection Selectable low pass filter and adjustable averaging Back-up memory in case of power failure 10 Product memory
Control Features	2 stage control valve for fast and slow filling Free-fall / Auto free fall compensation selection Automatic tare Restart / Resume mode Auto / Manual mode Automatic zero tracking Bung hole miss alarm Empty drum detection Safety interlock in event of power failure
Load Cell	VLC-131/2/3 Series, Virtual Measurements & Control, Inc , USA Single point, analog load cell IP65 protection against moisture ingress Aluminium construction / (Optinal : FM approved NEC Class 1 Div 1 / Hermetically sealed load cell)
Optional	Harzardous Environment Protection up to Class I, Div. 1, Gp CDEF, Nema 7 enclosure c/w safety barriers, ex-proof solenoid valves and sensors. Fume hood for fume recovery system Print output c/w panel mounted 50mm dot matrix printer Stainless Steel construction Top fill / bottom fill execution
Application	All liquid chemical product including viscose product like latex paint, oil, lacquers and paste.



Virtual Measurements & Control, Inc.
1040A N.Dutton Ave, Santa Rosa, CA 95401, USA
Tel : (707) 573 3111 Fax : (707) 573 3113
URL: <http://www.virtualmc.com>

Virtual Measurements & Control (Asia) Pte. Ltd.
24 Hillview Terrace, Singapore 669235
Tel : (65) 6762 5522 Fax : (65) 6763 6656
E-mail : sales@virtualmc.com

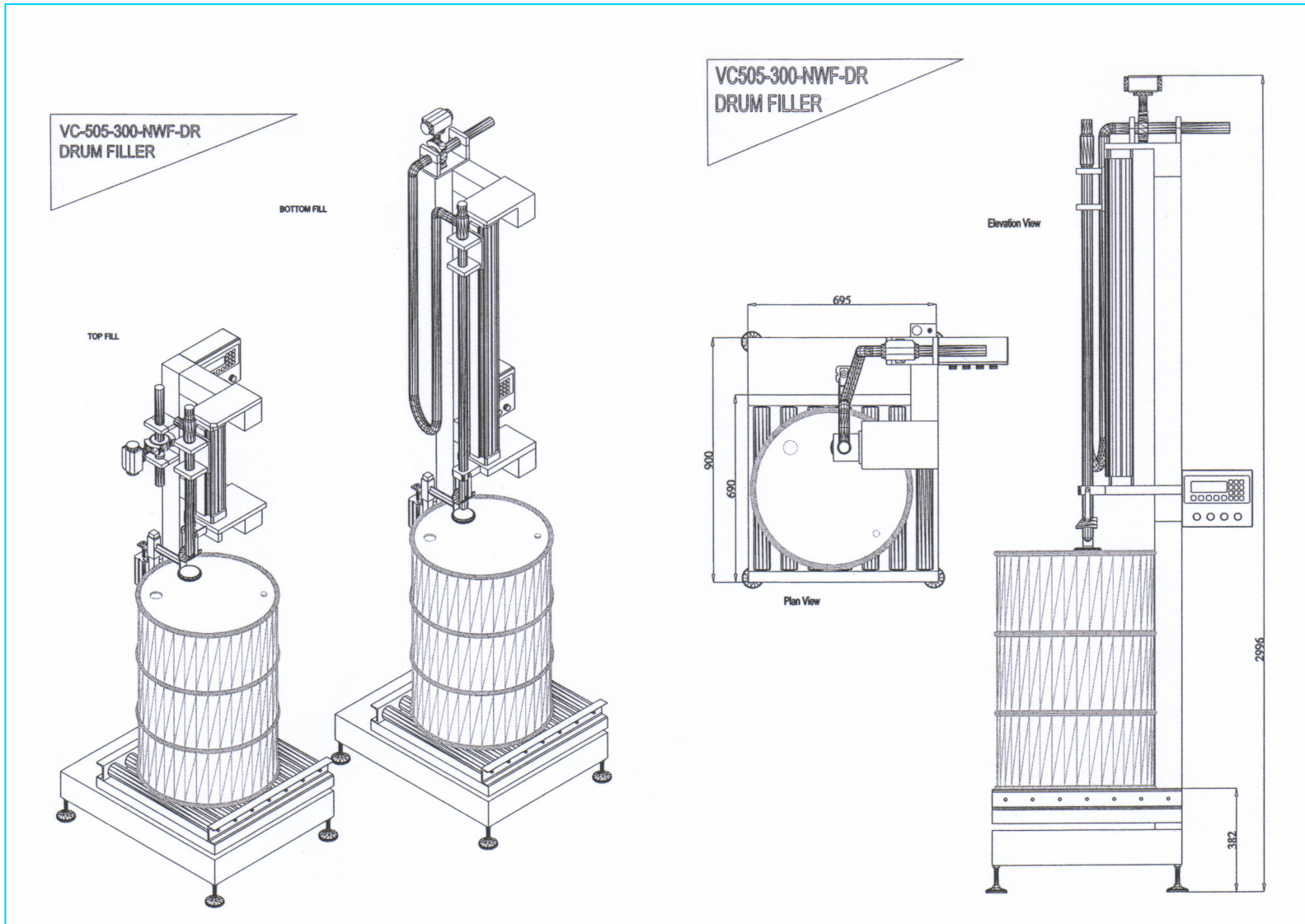

VC-505-30-NWF-PA
PAIL FILLER

VC505-30-NWF-PA
(Top Fill)

