



### Single Point Load Cell

# VLC-A132

#### APPLICATIONS

- Single Point platform scale
- Belt Conveyor
- Bench scales
- Check weighing
- Hopper Scales



#### STANDARD CAPACITY

60, 100, 250, 500, 635kg

#### WIRING

RED	Input (+)
BLACK	Input (-)
GREEN	Output (+)
WHITE	Output (-)

#### RECOMMENDED MAX. PLATFORM SIZE

600mm x 600mm

#### SPECIFICATIONS

Rated Output	2mV/V ± 10%
Non-Linearity	0.03% F.S.
Hysteresis	0.03% F.S.
Non-repeatability	0.02% F.S.
Creep (in 1 hr)	0.03% F.S.
Zero Balance	± 1%
Temp. effect span	15 PPM/°C
Temp. effect zero	26 PPM/°C
Operating Temp. range	- 20°C ~ + 60°C
Compensated Temp. range	- 10°C ~ + 40°C
Input resistance	385 ± 15Ω
Output resistance	350 ± 5Ω
Safe overload	150% F.S.
Ultimate overload	300% F.S.
Excitation voltage	10VDC/AC
Max. Excitation voltage	15VDC/AC
Insulation resistance	≥ 2000MΩ
Environmental protection	IP67
Material	Aluminum
Cable length	9FT

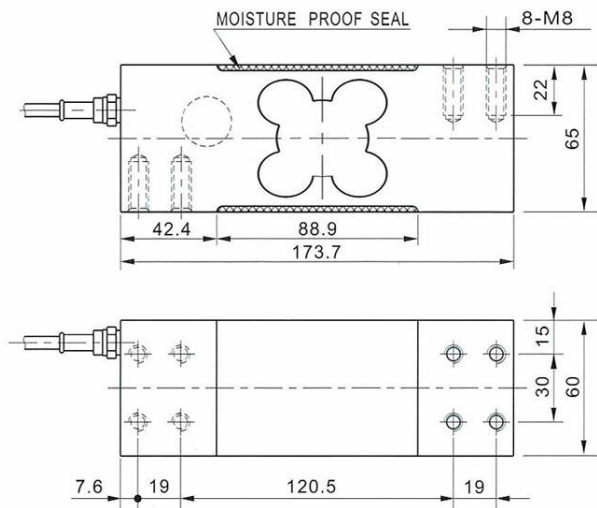

Dealer:



Virtual Measurements & Control Inc

Virtual Measurements & Control Inc

3196 Coffey Lane, Suite 604, Santa Rosa, CA95403  
Tel: (707) 573 3111 Fax: (707) 573 3113

Virtual Measurements & Control (Asia) Pte Ltd

24 Hillview Terrace, Singapore 669 235  
Tel: (65) 6762 5522 Fax: (65) 6763 6656