



Single Point Load Cell

VLC-A131

APPLICATIONS

- Single Point platform scale
- Belt Conveyor
- Bench scales
- Check weighing
- Hopper Scales



STANDARD CAPACITY

5, 10, 20, 30, 50, 100, 200lb

WIRING

RED	Input (+)
BLACK	Input (-)
GREEN	Output (+)
WHITE	Output (-)

RECOMMENDED MAX. PLATFORM SIZE

400mm x 400mm (15.75" x 15.75")

SPECIFICATIONS

Rated Output	2mV/V \pm 10%
Non-Linearity	0.03% F.S.
Hysteresis	0.03% F.S.
Non-repeatability	0.02% F.S.
Creep (in 1 hr)	0.03% F.S.
Zero Balance	\pm 1%
Temp. effect span	15 PPM/ $^{\circ}$ C
Temp. effect zero	26 PPM/ $^{\circ}$ C
Operating Temp. range	- 20 $^{\circ}$ C ~ + 60 $^{\circ}$ C
Compensated Temp. range	- 10 $^{\circ}$ C ~ + 40 $^{\circ}$ C
Input resistance	385 \pm 15 Ω
Output resistance	350 \pm 5 Ω
Safe overload	150% F.S.
Ultimate overload	300% F.S.
Excitation voltage	10VDC/AC
Max. Excitation voltage	15VDC/AC
Insulation resistance	\geq 2000M Ω
Environmental protection	IP67
Material	Aluminum
Cable length	5FT

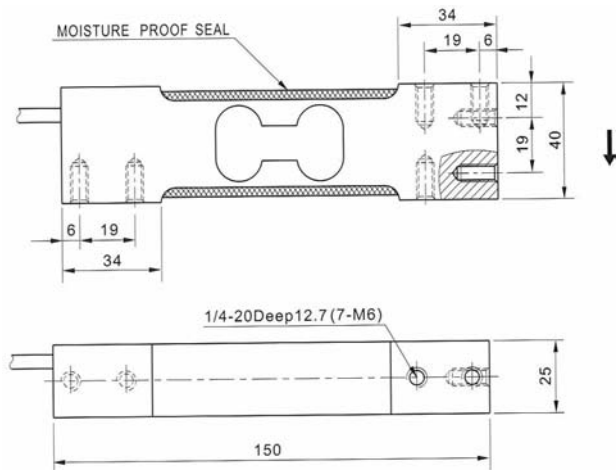

Virtual Measurements & Control Inc

Virtual Measurements & Control Inc

3196 Coffey Lane, Suite 604, Santa Rosa, CA95403
Tel: (707) 573 3111 Fax: (707) 573 3113

Virtual Measurements & Control (Asia) Pte Ltd

24 Hillview Terrace, Singapore 669 235
Tel: (65) 6762 5522 Fax: (65) 6763 6656

Dealer: